



CORDIS HIGH RESOLUTION ELECTRONIC PROPORTIONAL PRESSURE CONTROLS

Known for reliability, innovation and focus on miniature pneumatics, Clippard's new Cordis controls utilize the proven EVP and DVP lines of proportional valves allowing for steady, repeatable downstream pressure as demand or processes change. The result, a precise linear pressure control within a closed-loop system with ultra high resolution and repeatability.

Precise, linear pressure control within a closed-loop system with ultra high resolution and repeatability

Medium	Clean, dry, non-corrosive gases
Wetted Material	<i>Sensor: Polyamide, Manifold: Anodized Aluminum, Valves: please refer to the DVP or EVP specifications</i>
Valve Type	Normally-Closed
Operating Pressure Range	0 to 10 bar
Typical Flow	2.7 to 65 l/min ($\pm 10\%$ @ 7 bar)
Typical Response Time	<20 ms (application dependent)
Accuracy	$\pm 0.25\%$ of Full Scale
Resolution	≤ 5 mV
Max. Hysteresis	$\pm 0.05\%$ of Full Scale
Linearity	$\pm 0.05\%$ BFSL
Port Size	1/8" NPT, G1/8
Temperature Range	<i>Proportional Valve: 0° to 50°C</i>
Mounting Attitude	Any
Filtration	40 micron
More Details	clippard.com/link/cordis

Equipment used for test and calibration is NIST Traceable



Clippard's proven M-DVP and M-EVP proportional valves provide fast, stable control of pressure

The Cordis uses a microcontroller, integrated pressure sensor, and two Clippard proportional valves. The inlet valve is connected to the moderately regulated supply pressure and the exhaust valve is connected to a port that vents excess pressure to atmosphere. Once a command is increased, the inlet valve opens up to allow supply pressure to pass over the sensor element which provides an active feedback for the microcontroller to satisfy the set point in the process. If at any point the sensor detects a value higher than the set point, the exhaust valve will modulate open to vent off the excess pressure to maintain a stable and accurate control pressure in the process.

The Cordis is adaptable to a variety of sensors that can close the loop around not only pressure, but vacuum or flow.

Consult Clippard for application specifications to confirm viability.

- Smooth linear control
- Integrated internal or external sensor feedback
- Multiple flow configurations
- Static or dynamic applications with the same proportional control
- Proportional fill and bleed control
- Customizable pressure ranges and mounting options
- No integral bleed required

Voltage	15 to 24 VDC
Current Draw	<250 mA max.
Protection Rating	IP65 version available
Signal/Command	<i>Analog: 0 to 10 VDC Digital: 3.3 Volt Serial</i>



+32 10 45 21 34 | clippard.eu

CLIPPARD INSTRUMENT LABORATORY, INC. • ISO 9001 • TDS 1.19
For warranty and disclaimer information, visit clippard.com/warranty

ORDERING INFORMATION

Model	Type	Porting	Signal/Command	Pressure Range	Min. Volume/Flow @ Max. Pressure
CPC- Cordis Pressure Control	C Card Unit	F 1/8" NPT	E 0 to 10 VDC	-A 0 to 1 psig	A $\geq 4 \text{ cm}^3 / 2.7 \text{ l/min}$
	H Housed Unit	G G1/8	R 3.3 VDC Serial	-B 0 to 5 psig	B $\geq 8 \text{ cm}^3 / 6.7 \text{ l/min}$
Example Part No. CPC-CFE-GA			-C 0 to 15 psig	C $\geq 16 \text{ cm}^3 / 25.0 \text{ l/min}$	
<i>Consult Clippard for availability of non-standard commands and other options.</i>			-D 0 to 30 psig	D $\geq 32 \text{ cm}^3 / 65.0 \text{ l/min}$	
			-E 0 to 60 psig		
			-F 0 to 100 psig		
			-G 0 to 150 psig		
			-H 0 to 0,1 bar		
			-I 0 to 0,5 bar		
			-J 0 to 1 bar		
			-K 0 to 2 bar		
			-L 0 to 4 bar		
			-M 0 to 7 bar		
-N 0 to 10 bar					

Accessories

CPCH-C1 Actuation Cable, 8-Pin, 15 mm

CPCH-C2 3.3 VDC Serial Cable, 7.5 mm

CPCH-B1 Mounting Bracket

CA6 Power Cord, 6' (card unit only)

CPC-C Card Unit

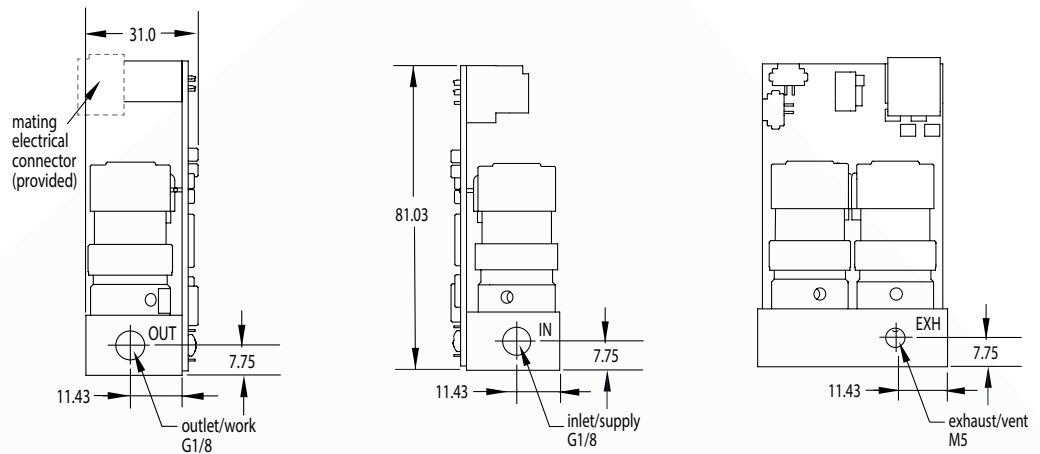

CPC-H Housed Unit

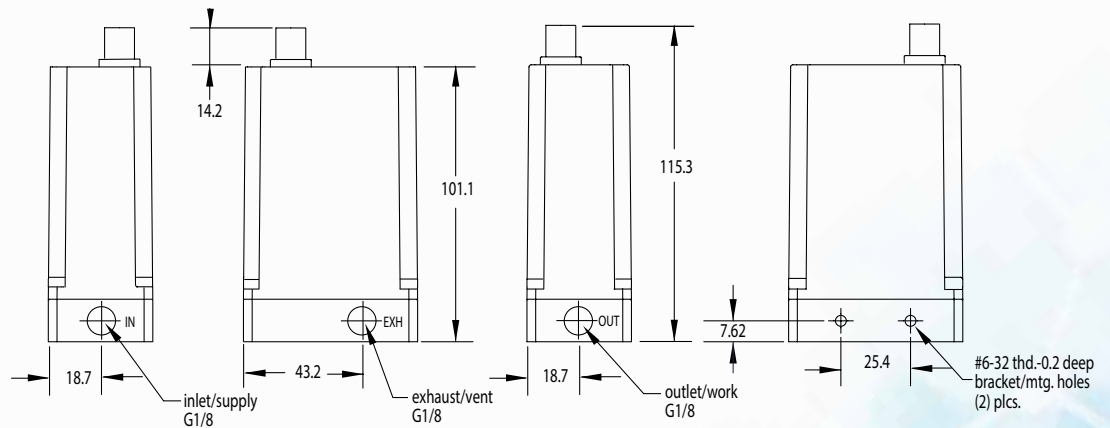

+32 10 45 21 34 | clippard.eu

CLIPPARD INSTRUMENT LABORATORY, INC. • ISO 9001 • TDS 1.19
For warranty and disclaimer information, visit clippard.com/warranty

